

VIBRO-RIPPER

Suitable excavators: 26500~143300 lbs



SPECIFICATION



- Noise restriction area
- Residential area & construction site
- Cracked rock and layered rock
- Open fit mining area and tunneling
- Foundations and wet places

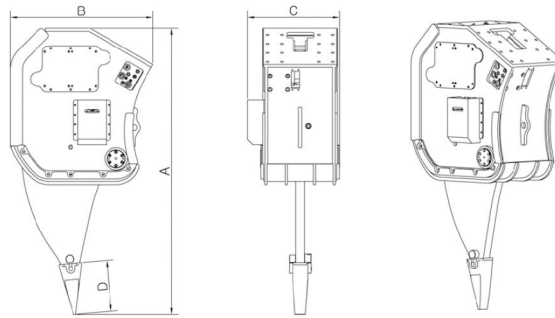

XTVR

XTERRA

VIBRO-RIPPER XTVR SERIES

Model		XTVR15	XTVR25H	XTVR25S	XTVR35H	XTVR35S	XTVR45	XTVR55	XTVR65
Carrier	Lbs	26500- 37500	39700- 59500	39700- 59500	61700- 77200	61700- 77200	79400- 92600	94800- 121300	123500- 143300
Weight (w/o bracket)	Lbs	2866	4189	4938	5423	6526	8289	9612	12254
Frequency	Vpm	1700	2500	1700	2500	1700	1700	1700	1700
Setting Pressure	PSI	3556	3556	3556	3698	3556	3556	3556	3556
Oil Flow	GPM	26.4-31.7	39.6-45	31.7-37	47.5-52.8	47.5-52.8	68.7-74	76.6-81.8	84.5-92.5
Air Pressure	BAR	4	4	3	4	4	3	3	3
Dimension H (A)	Inches	70	91	97	96	104	115	119	134
Dimension L (B)	Inches	41	43	48	45	52	57	59	64
Dimension W (C)	Inches	30	32	32	32	34	36	37	41
Dimension T (D)	Inches	10	19	19	19	19	19	23	23
Scope of supply	set	unit, mounting cap, hoses, tools, manual	unit, mounting cap, hoses, tools, manual	unit, mounting cap, hoses, tools, manual	unit, mounting cap, hoses, tools, manual	unit, mounting cap, hoses, tools, manual	unit, mounting cap, hoses, tools, manual	unit, mounting cap, hoses, tools, manual	unit, mounting cap, hoses, tools, manual

