

# Swingotilt®

ST28

Machines 22 - 30 tonnes



Extreme flexibility and maximum safety. The grease lubricated Swingotilt® enables the excavator arm to make one endless rotation and tilt up to 40° in each direction. This means that the arm and bucket can bypass various obstacles, release loads easier and reduce the need for manual assistance with maneuvers. Swingotilt® increases safety for both the driver and those around the excavator.

Swingotilt® ST28 is supplied complete with hydraulic hoses, hydraulic connections, wiring and installation manual.

ST28 can be adapted for most machines in the size range. It is available with most types of quick coupler systems, and a with direct mounted upper/lower section.



Available with double-acting cylinder or telescopic cylinder.

## TECHNICAL SPECIFICATION SWINGOTILT® ST28

Infinite rotation 360°  
Tilting 2 x 40°  
12/24VDC  
Grease lubricated

Valve system  
System Pro  
System P  
System TXSC  
System TXC  
System TS

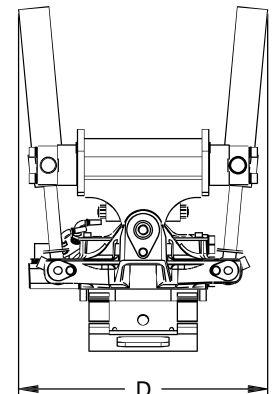
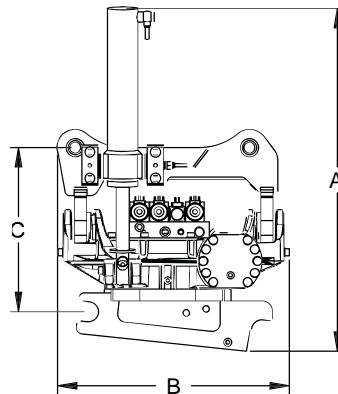

Mounting	B20 / S2 (B27)	S70	SMP1
Approx weight (kg)	760 (840)	730	740
Dimensions A / B / C / D	1130 / 1020 / 570 / 920	1080 / 920 / 670 / 860	1120 / 1040 / 710 / 870
Tilt angle	2 x 40°		
Rotation	Infinite 360°		
Oil flow Min / Max	50 / 100 L/min		
Operating pressure Min / Max	18 / 35 Mpa		
Tilt torque at 21 Mpa	52,88 kNm		
Rotation speed	10 sec / rotation		
Torque	7000 Nm		

Weights can vary depending on design of product