

Swingotilt®

ST10

Machines 6 - 10 tonnes



Extreme flexibility and maximum safety.

The grease lubricated Swingotilt® enables the excavator arm to make one endless rotation and tilt up to 40° in each direction. This means that the arm and bucket can bypass various obstacles, release loads easier and reduce the need for manual assistance with maneuvers. Swingotilt® increases safety for both the driver and those around the excavator.

Swingotilt® ST10 is supplied complete with hydraulic hoses, hydraulic connections, wiring and installation manual. ST10 can be adapted for most machines in the size range. It is available with most types of quick coupler systems, and with a direct mounted upper/lower section.



Available with double-acting cylinder or telescopic cylinder.

TECHNICAL SPECIFICATION SWINGOTILT® ST10

Infinite rotation 360°
Tilting 2 x 40°
12/24VDC
Grease lubricated

Valve system
System Pro
System P
System TXSC
System TXC
System TS

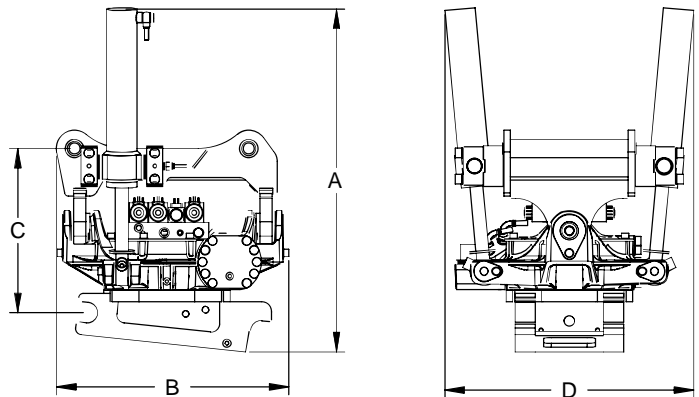

Mounting	S45 / S50	SMP3
Approx weight (kg)	260	260
Dimensions A / B / C / D	870 / 590 / 430 / 600	890 / 640 / 480 / 600
Tilt angle	2 x 40°	
Rotation	Infinite 360°	
Oil flow Min / Max	30 / 60 L/min	
Operating pressure Min / Max	18 / 21 Mpa	
Tilt torque at 21 Mpa	25,3 kNm	
Rotation speed	7 sec / rotation	
Torque	5000 Nm	

Weights can vary depending on design of product